



Installation Instructions

These instructions cover the preparation of doors to be fitted into a pocket that has the **CS SofStop Track** fitted.

Read through the notes carefully before beginning as different mounting plate positions and setups may be required for different configurations.

IMPORTANT

The CS SofStop carriages require a clean track running surface free of any contamination or damage.

After installation but before lining, **clean the full length of the inside running surface of the track with a soft rag, then TAPE UP THE TRACK to ensure no dust or debris enter the track during building works.**

Never drill, nail or screw through the center section of the track. Make sure no dirt, grit or aluminum swarf gets into the track. This could impair the smooth running of the carriages.

1 Prepare the doors.

Drill two holes in the positions as marked (right). Screw both mounting plates to the door with the plunger pins facing towards the edges of the door. Make sure they are placed exactly in the center of the door thickness.

At the bottom of the door, cut a groove to the dimension and tolerance shown. Make it central of the door thickness and absolutely straight.

2 Bi-Parting (double) doors.

The mounting plate with the black plastic stop fits nearest to the leading edge of the door.

3 Fix the T-Guide.

Fix the T-Guide to the floor so that it is not visible when the door is in the pocket. The front edge of the T-Guide should sit flush with the final casings.

Go to page **2** (overleaf) 

PREPARING DOORS - Single

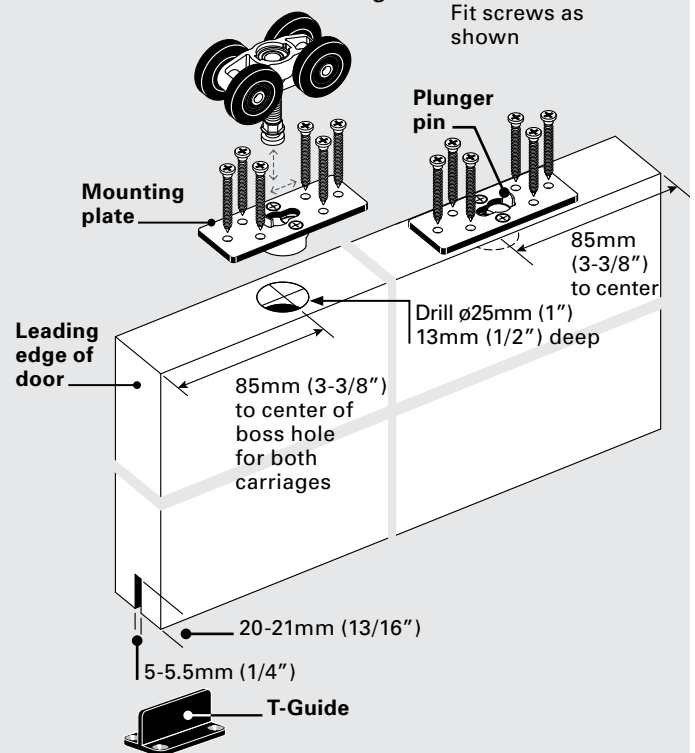

PREPARING DOORS - Bi-Parting (double)-or Mount Plate with Stop

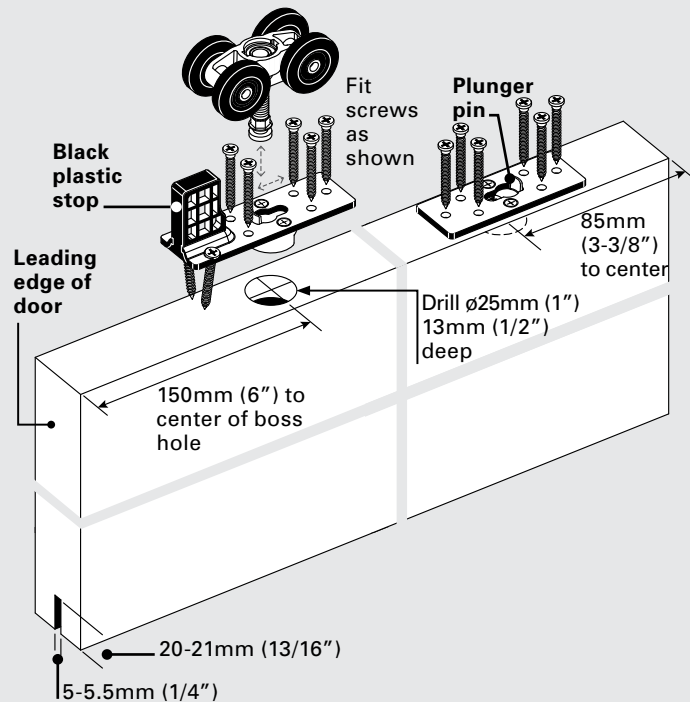

SUGGESTED T-GUIDE PLACEMENT

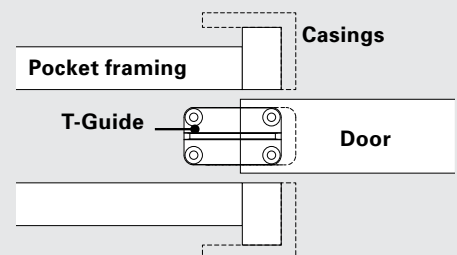

4 Install the SofStop mechanism.

Note: For Twin (Soft Open & Soft Close) mechanism, go to instruction 10, overleaf.

If the pocket frame has been supplied with head jambs fitted, remove the jamb from one side to allow access to carriages for mounting and vertical height adjustment. Refix the head jamb once door has been mounted and desired door clearance is achieved.

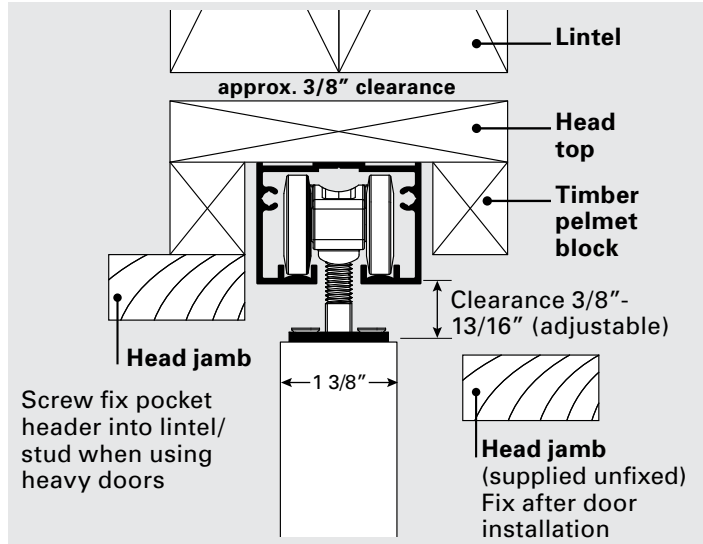

Single Action Soft Close

The SofStop mechanism fits together as shown:

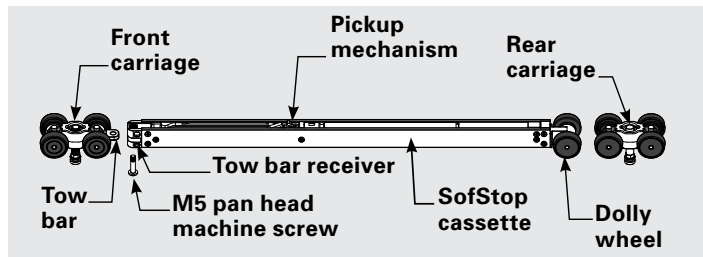

4 To load the SofStop mechanism into the track:

a) First, slide the rear carriage in from the notched end of the track. Note: Rear carriage does not have a tow bar.

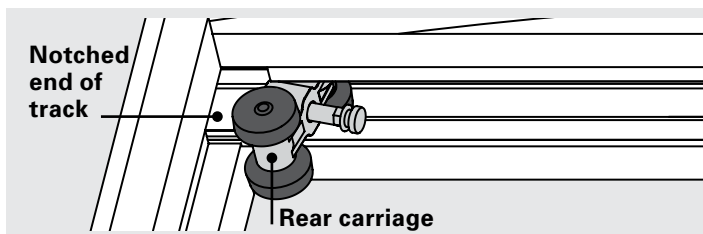

b) Insert the cassette into the notched end of the track, dolly wheel first, ensuring that the pickup mechanism is facing up.

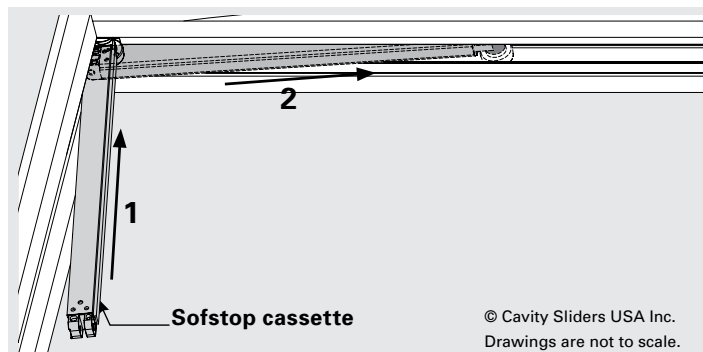

c) Slide the front carriage into the track with the tow bar facing into the pocket.

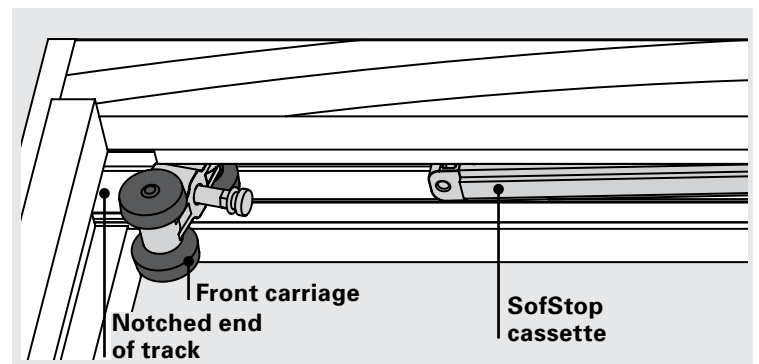

d) Secure the carriage to the cassette with the M5 pan head machine screw. Tighten with a #2 Phillips drive.

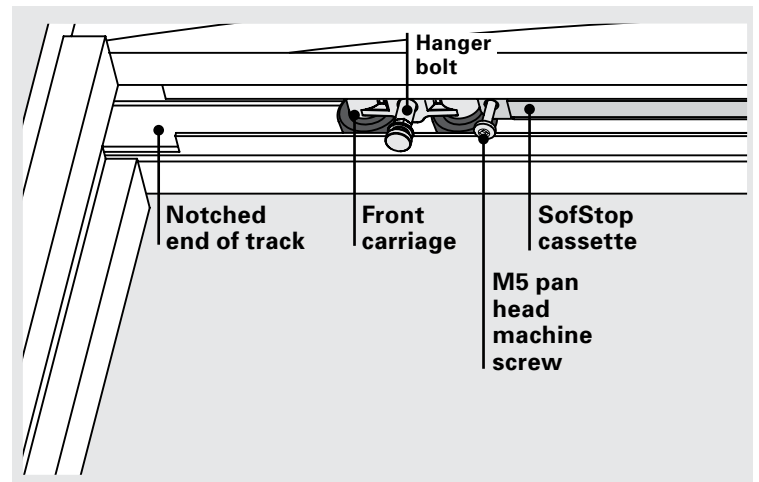

5 Hang the door(s).

Position the carriages in the pocket opening approximately where the mounting plates on the door will be located when the door is in the closed position.

Slide the door over the T Guide and into the pocket.

Align the mounting plates with the hanger bolts of the carriages.

Raise the door up so that the round head of the wheel hanger shaft lines up with the keyhole shaped hole in the mounting plate.

Depress the plunger using the wheel hanger shaft head and slide sideways until it snaps into locked position. Repeat for the other carriage.

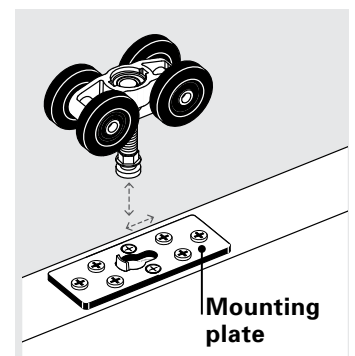

6 Adjust the door height.

When adjusting door height, the wrench should be horizontal to the nut.

Use the small end of the wrench supplied to rotate the hexagonal nut at the bottom of the carriage hanger shaft.

To **raise** door: Rotate wrench from **left to right**.

To **lower** door: Rotate wrench from **right to left**.

Note: The top of the hanger shaft screws into a self-locking nut. If the hexagonal nut is turned counter clockwise too far, the shaft will become loose from the self-locking nut. If the turning resistance suddenly feels much easier, you have gone too far.

Single Action Soft Close

- 6 If you raise the door to the maximum height position, the threaded bolt may contact fixing screw heads. If required, remove hanger bolt from wheel and remove 2-3mm (1/8") of thread.

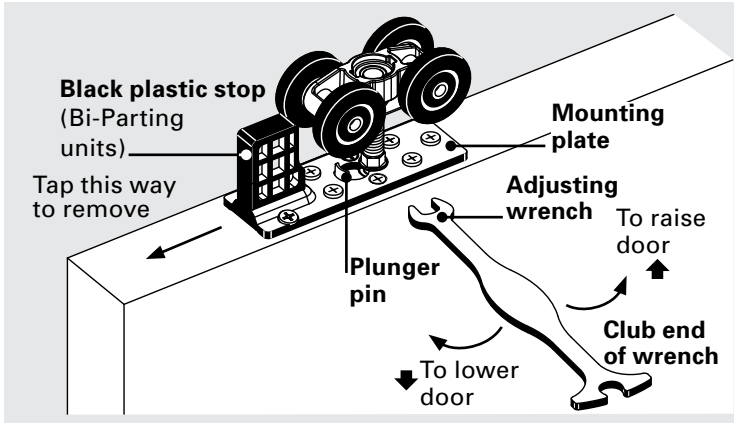

6 Set the activator position

- a) Open the door and insert the activator, moving it into the approximate center of the door opening. Tighten one grub screw.

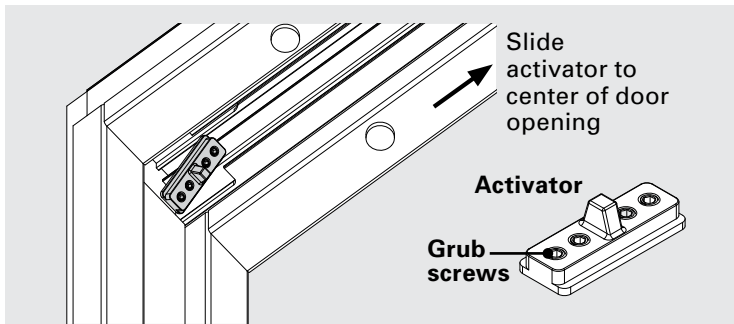

- b) Slowly close the door until the pickup mechanism goes past the activator. You will hear a click. The cassette is now charged. Open the door again and loosen the grub screw.
c) Position the activator setting block inside the closing jamb and gently close the door onto it. The activator will slide along the track into the correct position.

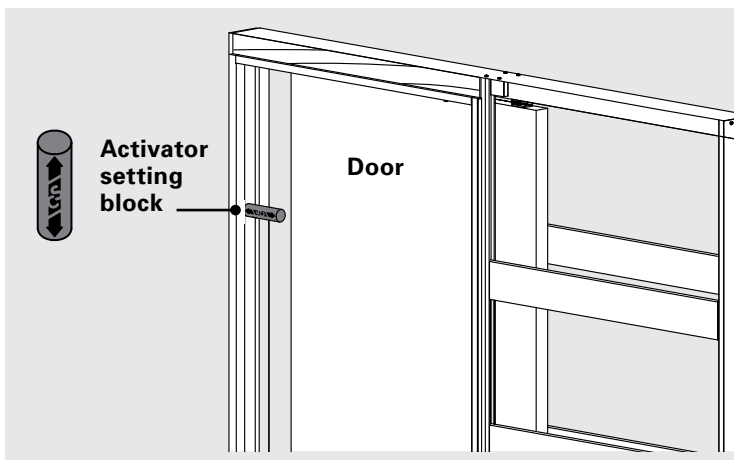

- d) Open the door and remove the activator setting block. Without moving the activator, tighten all four grub screws. The activator is now positioned.

Note: Some doors may still bump on the closing jamb when closing. If this is a concern, a 3M clear dome stop (or similar) can be used.

7 Bi-Parting (Double) doors.

Slide the track stop into the track via the carriage removal notch and loosely tighten so that the track stop is still able to slide.

Use the door to push the track stop to where you want the door to stop. Slide the door away and tighten the track stops using a hex key.

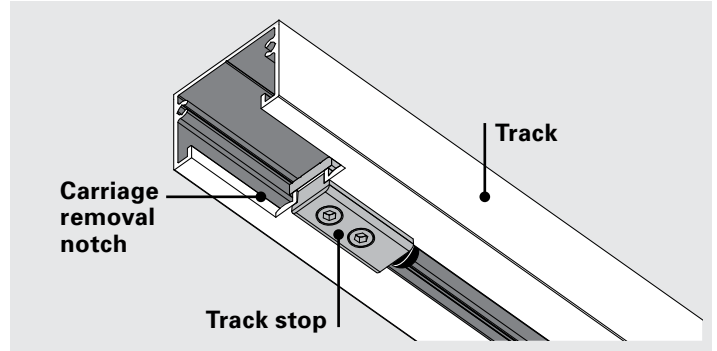

8 Removing the door(s) (for painting, repairs etc).

Fit the club end of the adjusting wrench over the hexagonal nut at the bottom of the hanger pin.

Use the extended part of the wrench to press down the plunger pin that protrudes up from the mounting plate.

Once this plunger is fully depressed slide the wrench sideways towards the plunger pin.

The whole carriage (including the shaft) will now disengage from the mounting plate.

It is not always easy to slide the wrench sideways. You may need to relieve the door's weight by putting a wedge between door and floor.

Bi-Parting doors: Remove the black plastic stop that is tightly fitted into the mounting plate by tapping it out in the direction shown using a hammer and drift.

9 Removing the SofStop mechanism

If you need to remove or service the cassette, begin by removing the door leaf (instruction 8).

Loosen the M5 pan head machine screw and slide the front carriage towards the closing jamb until it can be removed via the notch. Repeat for the cassette and rear carriage.

SofStop Twin: Go to page **4** (overleaf)

Cavity Sliders USA Inc.
548 Finney Ct, Gardena, CA 90248
Phone: (888) 466 0030
Fax: (310) 769 5824

Another quality product from:

CavitySliders
Quality Sliding Door Hardware

info@cavitysliders.com
www.cavitysliders.com

© All copyright and other property in this document is reserved by Cavity Sliders USA Inc. Details and specifications are subject to change without notice. Whilst all care is taken to ensure the accuracy of all information, no responsibility will be accepted for any errors or omissions.

CS SOFSTOP™ (O.D. 2012). 09.2017 - ZNI125 / 60721/US

SOFSTOP TWIN MECHANISM

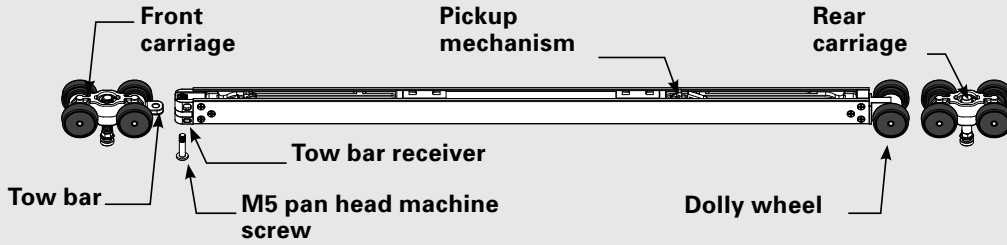

IMPORTANT: the Sofstop Cassette has been supplied set by the manufacturer. It is important that it is not tampered with prior to installation.

10 SOFSTOP TWIN MECHANISM

To load the SofStop mechanism into the track:

- a) Insert the first activator into the notch in the track and slide it to the end of the pocket. **Do not tighten the screws - this position is temporary.**

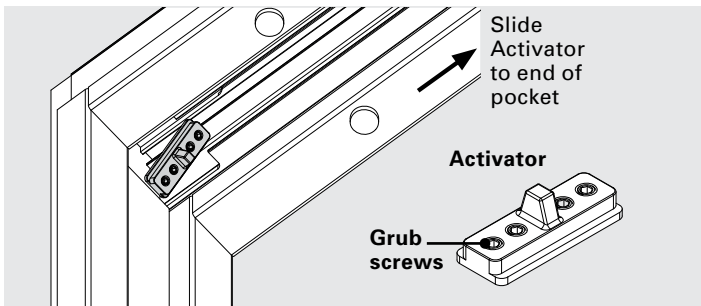

- b) Insert the rear carriage in from the notched end of the track. Note: Rear carriage does not have a tow bar.

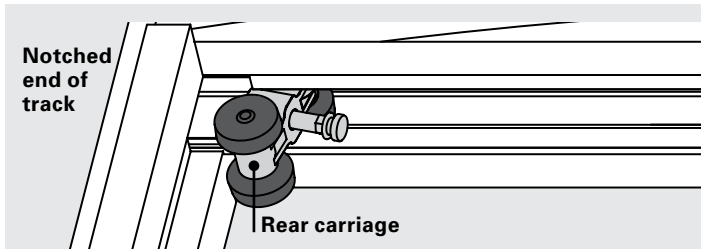

- c) Insert the cassette into the notched end of the track, dolly wheel first, ensuring that the pickup mechanism is facing up.

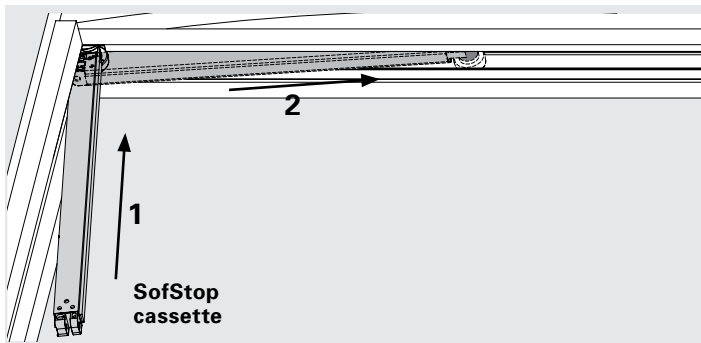

- d) Slide the front carriage into the track with the tow bar facing into the pocket.

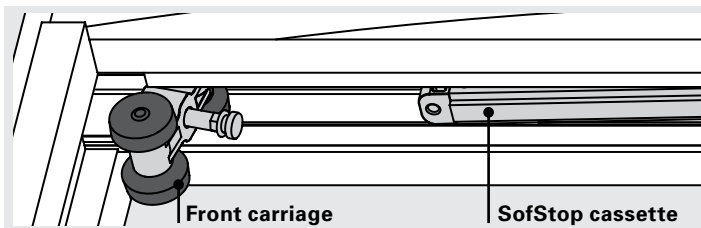

- e) Secure the carriage to the cassette with the M5 pan head machine screw. Tighten with a #2 Phillips drive.

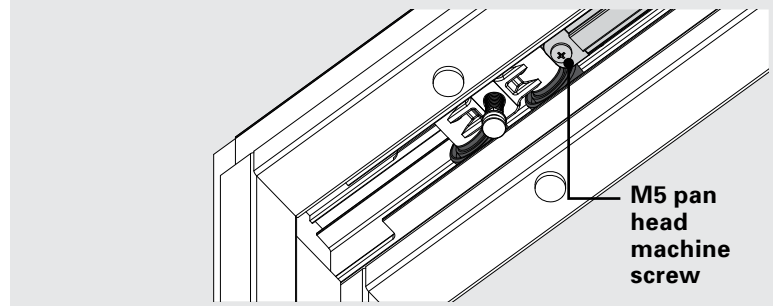

- 11 Hang the door. See instruction 5, overleaf.

12 Set the activator positions.

- a) With door in closed position move the first activator into approximate center of pocket. **Do not tighten screws.**
 b) Position the activator setting block inside the back stud and gently open the door onto it. The activator will slide along the track into the correct position.

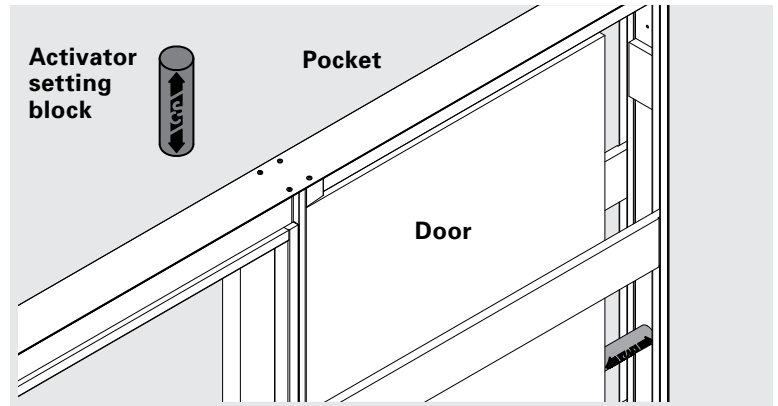

- c) Close the door and remove the activator setting block. Without moving the activator, tighten all four grub screws.
 d) Open the door and insert the second activator, moving it into the approximate center of the door opening. Do not tighten the grub screws.
 e) Position the activator setting block inside the closing jamb and gently close the door onto it.
 f) Open the door and remove the activator setting block. Without moving the activator, tighten all four grub screws.

The activators are now positioned.

Note: Some doors may still bump on the closing jamb when closing. If this is a concern, a 3M clear dome stop (or similar) can be used.

